

Droplet based microfluidics

With the Opto digital inverse microscope profile M

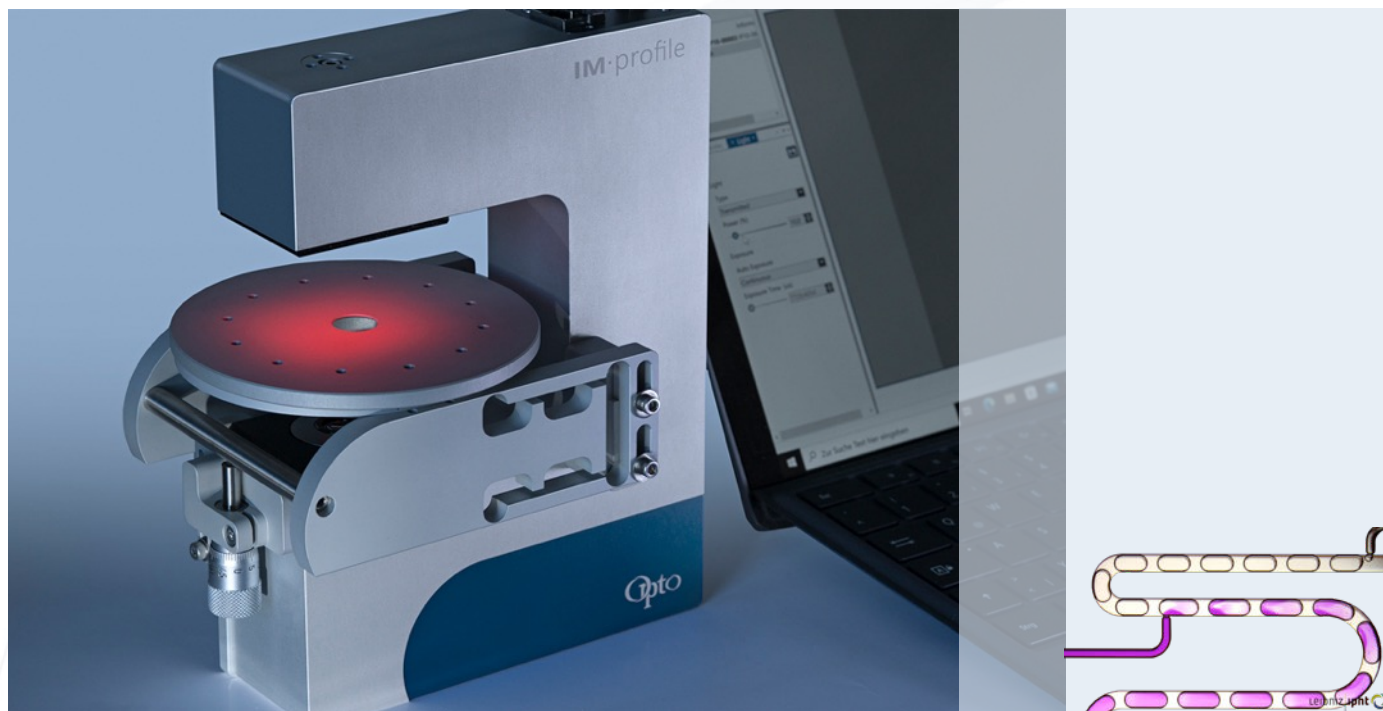

Fig. 1: The Opto Imaging Module profile M is a pure digital inverted microscope perfectly designed for microfluidic experiment

Droplet-based or digital microfluidics is a screening method used in various applications in practice. It creates serial sequences of droplets that are considered as self-contained reaction vessels. Spatially separated biological or chemical reactions or kinetics are done in these reaction vessels. Due to the very small reaction spaces in the picoliter range, the reactions run much faster compared to conventional procedures. This ends in reagent savings and significant time reduction, as well as the ability to highly automate screening experiments. Applications range from fast analytical systems, synthesis of materials to biological assays with living cells.

The principle behind droplet generation is based on the immiscibility of two liquids. During the transition of the two liquids, a phase boundary is formed, resulting in the formation of droplets.

The reaction process is usually fast. For this purpose, optical detection methods are used for the recognition and evaluation of these processes.

Challenging for the integration of microfluidic chip devices are the limited available packaging space. Therefore, inverted microscopes with long working distances are preferred for these applications.



Fig. 2: profile M in function



In order to follow chemical or biological reaction kinetics, it is necessary to resolve the reactions in temporal and spatial resolution. Multifluorescence digital microscopes, high speed image acquisition modules and easy cloud computing functionality integrated in an ultra-compact form factor is needed to realize a high throughput analysis. This is what the Opto Imaging Modules are designed for. The need for more point of care testing and high throughput screening solutions makes image-based cell analysis and lab on a chip approach more and more attractive. To integrate microscopy in compact instruments together with machine vision functionality needs the interpretation from microscopes as vision sensors. They must be smaller, more robust, with fast image acquisition interfaces and with an open Software architecture to be implemented in advanced benchtop analysis machines.

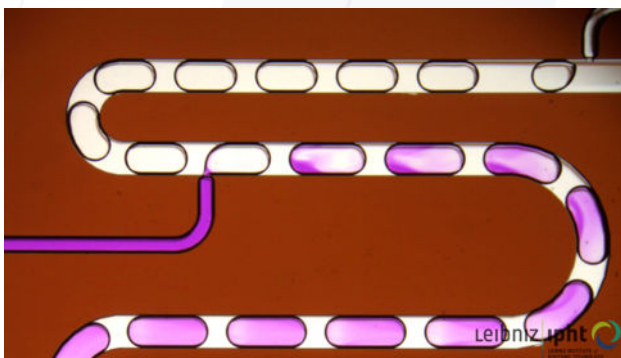

Fig. 3: Microfluidic droplet generation process with a additional dosing unit (red dye dosing)



Fig. 4: In comparison, the great progress of today's technological possibilities can be seen perfectly

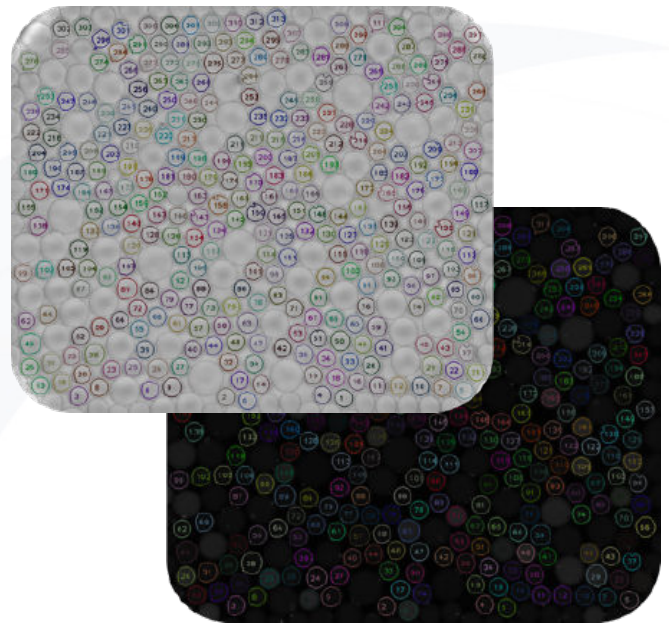

Fig. 5: Image-based evaluation process of the results. Bright field image (top left). All droplets that fulfil the pre-defined parameters are included in the analysis. Fluorescence image (bottom right)

A practical application for the droplet-based microfluidics is the digital polymerase chain reaction (dPCR). A fluorescence-based readout is used to detect biomolecules in sample solution. Digital droplet-based assays are offering promising opportunities for the absolute quantitation of low concentrated analyte species.

During the amplification process, the molecules amplified in the reaction chamber. After the amplification the droplets with DNA (positive) inside become fluorescent. Absolute quantitation of the number of target molecules is simplified to the count of fluorescence active droplets in the generated droplet collection. Statistical significance is achieved by counting up to 20,000 droplets per mm². The number of positive droplets is proportional to the amount of DNA used in the target sequence.

Besides traditional white light microscopy, fluorescence Imaging Modules allow dPCR in a completely new way and compactness. Co-developed market driven applications from Opto with R&D partners like the Leibniz-IPHT in Jena and leading microfluidic companies like Fluigent or ChipShop drives the industrialization of image-based PCR testing.

The encapsulation of cells or particles is common technique in droplet-based microfluidics to create defined reaction conditions. A high spatial and spectral resolution is necessary to detect optical and spectral shifts inside the droplets. The concentration of analytes and cells as well as the size of the droplets depends on the selected flow parameters and channel geometry. To adjust the speed, size of the droplets and to control the creation of the droplets, upright or transmitted light microscopes are used. Depending on the size of the droplets and particles inside the droplet as well as the chip design, different Imaging Modules are available to respond to the specific imaging need. Often space restrictions, optical accessibility in overall size, working distance or automation needs requires compact microscopes.

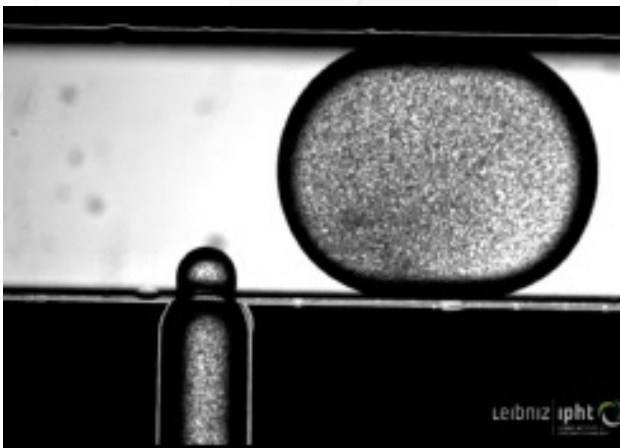

Fig. 6: Cell encapsulation process into a droplet

The required magnification depends on which details within the sample are to be resolved. Typically, standard magnifications of 5x, 10x and 20x are used for the image-based analysis of droplets in digital microscopy.

System Mag.	FoV [mm]	WD [mm]	NA	Resolution [LP/mm]	Object Space [$\mu\text{m}/\text{Px}$]	DoF [mm]	Image
20 x	0.4 x 0.4	3.6	0.45	810	0.2	0.003	mono
20 x	0.4 x 0.4	3.6	0.45	900	0.2	0.003	colour
10 x	0.8 x 0.7	13	0.30	630	0.3	0.008	mono
10 x	0.8 x 0.7	13	0.30	710	0.3	0.008	colour
5 x	1.7 x 1.4	31	0.10	250	0.7	0.05	mono
5 x	1.7 x 1.4	31	0.10	280	0.7	0.05	colour

Fig. 7: Specification

The advantage of droplet-based microfluidics is that the droplet size and volume can be precisely adjusted. This ensures the comparability of experiments due to the uniform size. In addition, the droplets are easier to control, handle and sort. Furthermore, the droplets can be manipulated by adding or removing liquids. Therefore, for example, cells are enclosed in droplets and subsequently separated on the basis of their spectral or morphological properties.

Due to the large number of possible geometries and functional units, complex experiments and multi-step synthesis can be realized within these structures.

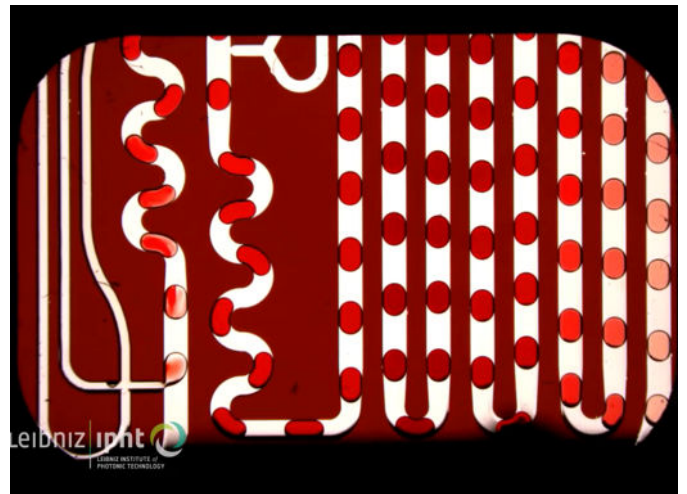

Fig. 8: Microfluidic chip design with different functional units for complex multi-steps synthesis.

In channels with small cross-sections laminar flow conditions prevail. The mixing of the droplets is realized by the arrangement of arch structures. The control of the mixing behavior must be monitored spatially and temporally. A typical field of application is the recording of reaction kinetics.

The channels are used to maintain the residence time and thus the incubation time. The evaluation of the experiments takes place at multiple measuring points in the Field of view.

Our fluorescence imaging modules allow to automate new microfluidic applications that have to find their way out of stand-alone R&D setups into point-of-care devices. Applications like copy number variation (CNV), rare sequence detection, gene expression, single-cell analysis and pathogen detection are applications that need newest imaging technologies. Multifluorescence digital microscopes, High speed Image acquisition and easy cloud computing functionality integrated in an ultra-compact form factor is needed to realize a high throughput analysis. This is what the Opto Imaging Modules are designed for.

We automate Microscopy - perfect contrasted images for Biomedical and Life Science applications. Multifluorescence, double view to substitute zoom or only a high resolution image. Together with X-Y-Z automation for machine integration or your own software development for your OEM application. All out of one Hand.

In many cases, the development and automation of new microfluidic processes needs to be monitored or evaluated optically. Image processing algorithms or image analysis tools are used for this purpose. This requires a well-contrasted basic image in order to automatically determine the droplet size and velocity with defined threshold configurations. Here, the high-quality optics of the Opto Imaging Modules and the matched illumination provide high-resolution, repeatable image data

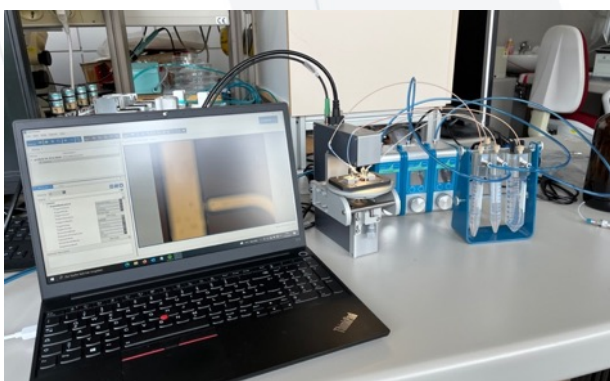

Autor: Daniel Kraus | 04/2022

Design and technical development are subject to change without notice. | © Opto GmbH | LS_M_M_IP_22-01.2

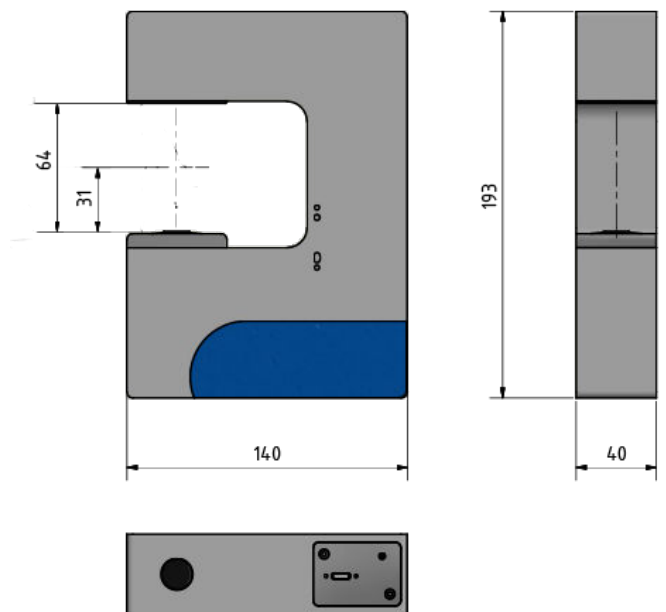
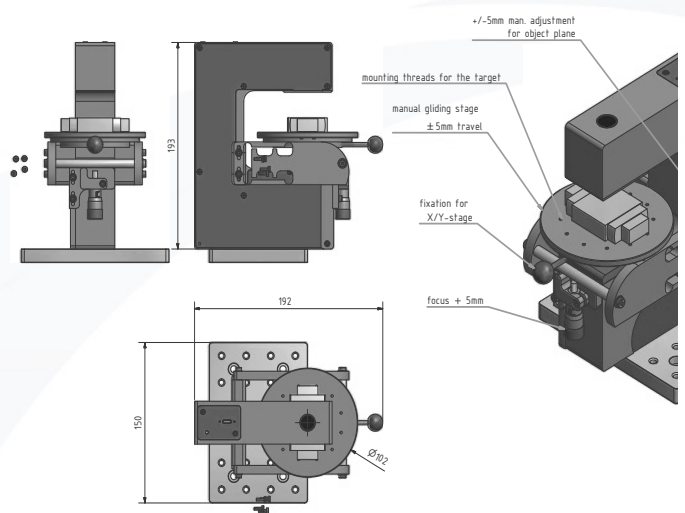

Fig. 9, 10: Technical drawing

Advantage for customer:

- Pure all in one digital microscope
- Nano / pixel Resolution with large FoV
- High Contrast and Color stability
- Repeatability of Image
- Open software architecture
- Easy machine integration
- Ultra compact design